

# 78 & 01 Instructions

SKU: MIU-\*\*78, MIU-\*\*01

78

01

Preparation:  
Before installing your new purchase please read and understand these instructions fully and make sure you have the required tools at hand.

1. Firstly, remove the original bar end.
3. Loosen the screws to your handlebar control gear, this will allow you to adjust the position of your controls so that a portion of the handlebars is exposed to mount the clamp (2).
4. Install the handlebar clamp (2) so that it is flush with the end of your handlebars, lightly tighten the M6 bolt(1) and refit your bar end to ensure correct positioning of the clamp (2), adjust as required.
5. Take a few moments to carefully position the handlebar clamp rotationally on the handlebar, it is usually best positioned upright, and as far forward as possible. Although of course you can also 'hang' the mirror from under the bars for a different look.
6. Tighten the M6 bolt (1) to secure the final position of the handlebar clamp; a small drop of thread lock can be applied for a permanent fixing if required.
9. Now adjust the mirror to its 'ideal' position. Check the position and re-adjust as necessary.
10. Repeat for the other handlebar side if you have purchased a pair of mirrors.
11. Recheck the tightness of all fastenings, including the M3 Torx(T10) bolts (3) for security.
12. We suggest you apply a very small amount of thread locker to all fasteners. DO NOT use red Loctite. Periodically recheck all fastenings for tightness.

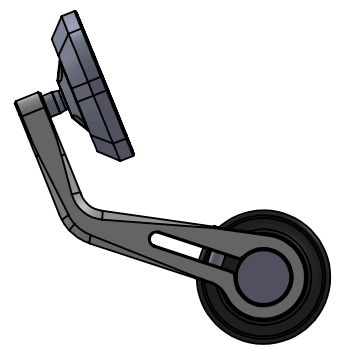
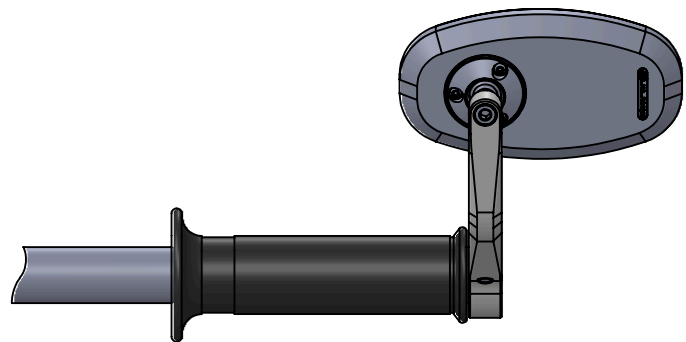
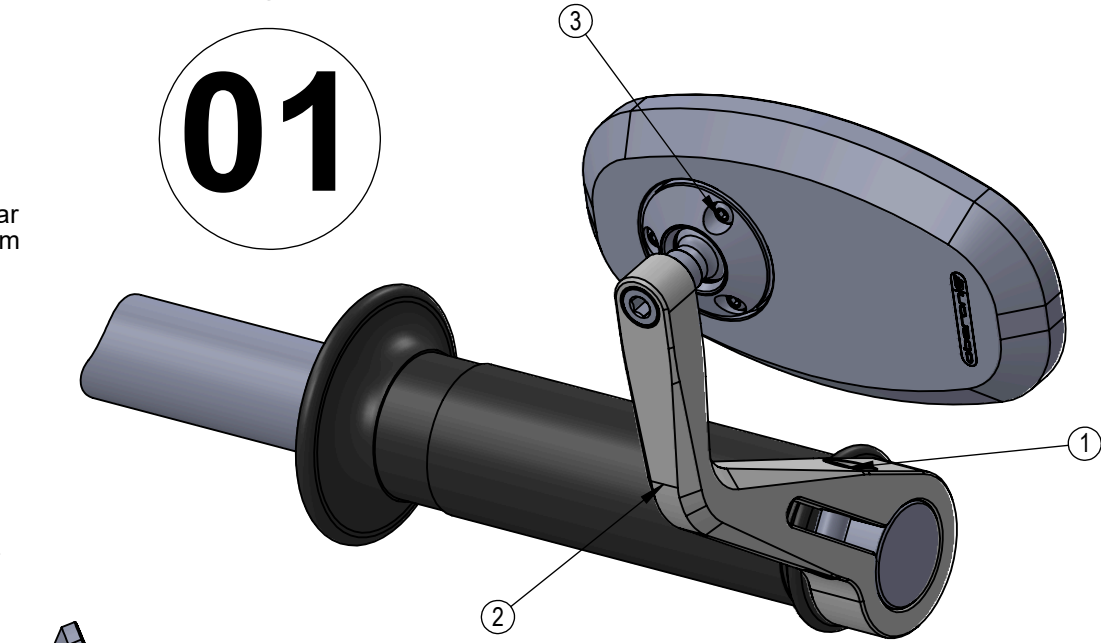

DO NOT SCALE DRAWING		REVISION:	
TITLE: <h2>Urban Mirror</h2>			
DWG NO:		A4	
SCALE:			

**PROPRIETARY AND CONFIDENTIAL**

THE INFORMATION CONTAINED IN THIS DRAWING IS THE SOLE PROPERTY OF OBERON PERFORMANCE LTD. ANY REPRODUCTION IN PART OR AS A WHOLE WITHOUT THE WRITTEN PERMISSION OF OBERON PERFORMANCE LTD IS PROHIBITED.

# 06, 08 & 10 Instructions

SKU: MIU-\*\*06, MIU-\*\*08, MIU-\*\*10

06

08

10

**Preparation:**

Before installing your new purchase please read and understand these instructions fully and make sure you have the required tools at hand.

1. Firstly, remove the original bar end.
2. Place the handlebar clamp (2) over the barend (5) and fix the unit to the end of the handlebars with the M6/M8/M10 bolt (1) depending on your fitting kit.
3. Adjust the clamp poition and fully tighten the M6 bolt (4). The clamp is best positioned as far forward as possible and can be mounted below if required.
4. Take a few moments to carefully adjust the mirror bezel to the correct position.
10. Repeat for the other handlebar side if you have purchased a pair of mirrors.
11. Recheck the tightness of all fastenings, including the M3 Torx(T10) bolts (3) for security.
12. We suggest you apply a very small amount of thread locker to all fasteners. DO NOT use red Loctite. Periodically recheck all fastenings for tightness.

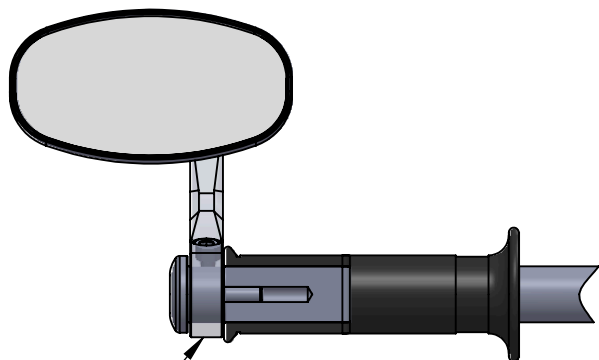
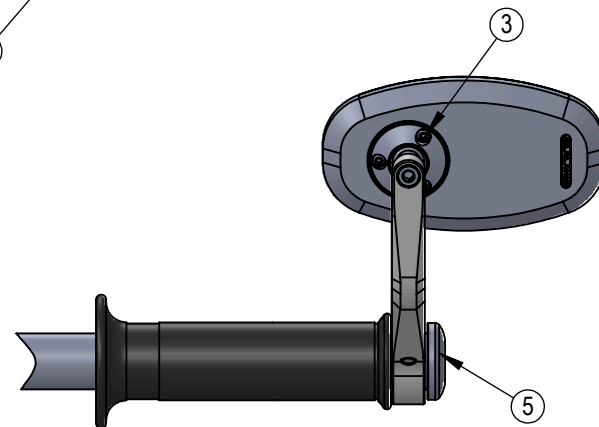
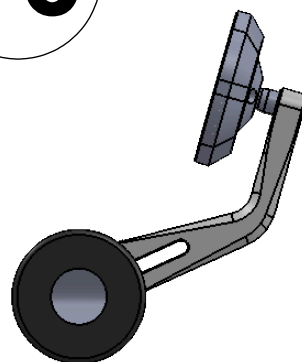
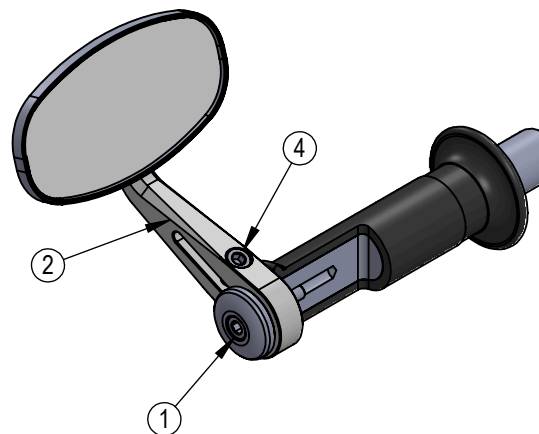

Clamp placed over barend

DO NOT SCALE DRAWING		REVISION:
		
TITLE: <h1>Urban Mirror</h1>		
DWG NO:	A4	
Installation Instructions		
SCALE:		

**PROPRIETARY AND CONFIDENTIAL**

THE INFORMATION CONTAINED IN THIS DRAWING IS THE SOLE PROPERTY OF OBERON PERFORMANCE LTD. ANY REPRODUCTION IN PART OR AS A WHOLE WITHOUT THE WRITTEN PERMISSION OF OBERON PERFORMANCE LTD IS PROHIBITED.

# 16 Instructions

**Preparation:**

Before installing your new purchase please read and understand these instructions fully and make sure you have the required tools at hand.

1. Remove the original bar end if present.
2. Check that the internal bore is clear of obstructions and burrs. Select the largest collet that will fit into the hole with out forcing it in.
4. If one of the aluminium adaptors is a closer fit, slide this over the 14mm brass collet with the open end of the machined slots facing outwards.
6. Place the mirror clamp(1) and adaptor over the bar end(3) and push the mirror bar end into the handlebar using a 5mm hex drive key. Fully tighten the bolt(5).
7. Lightly tighten the M6 bolt(2) on the clamp. Take a few moments to carefully position the handlebar clamp rotationally on the handlebar. The clamp is usually best positioned as for forward as possible for best vision. Alternatively the mirror can be hung upside down off the handlebar.
6. Tighten the M6 bolt (2) to secure the final position of the handlebar clamp; a small drop of thread lock can be applied for a permanent fixing if required.
9. Spend as much time as you needed to adjust the mirror to its 'ideal' position. Check the position and re-adjust as necessary.
10. Repeat for the other handlebar side if you have purchased a pair of mirrors.
11. Recheck the tightness of all fastenings, including the M3 Torx(T10) bolts (4) for security. Periodically recheck the tightness of all fixings.
12. We suggest you apply a very small amount of thread locker to all fasteners. DO NOT use red Loctite. Periodically recheck all fastenings for tightness.

16

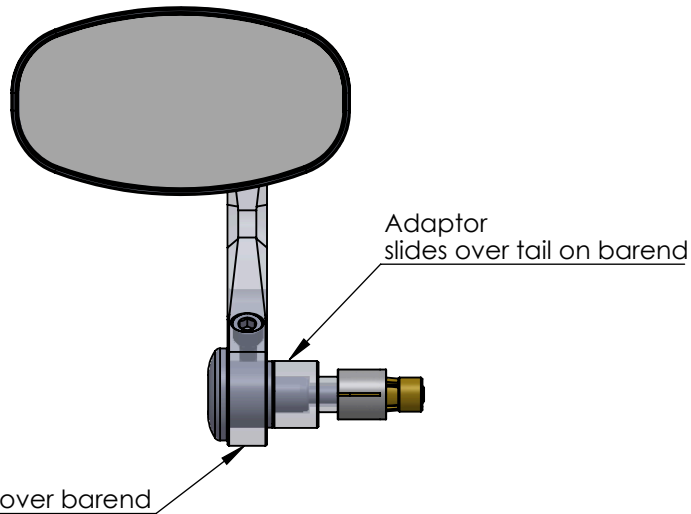
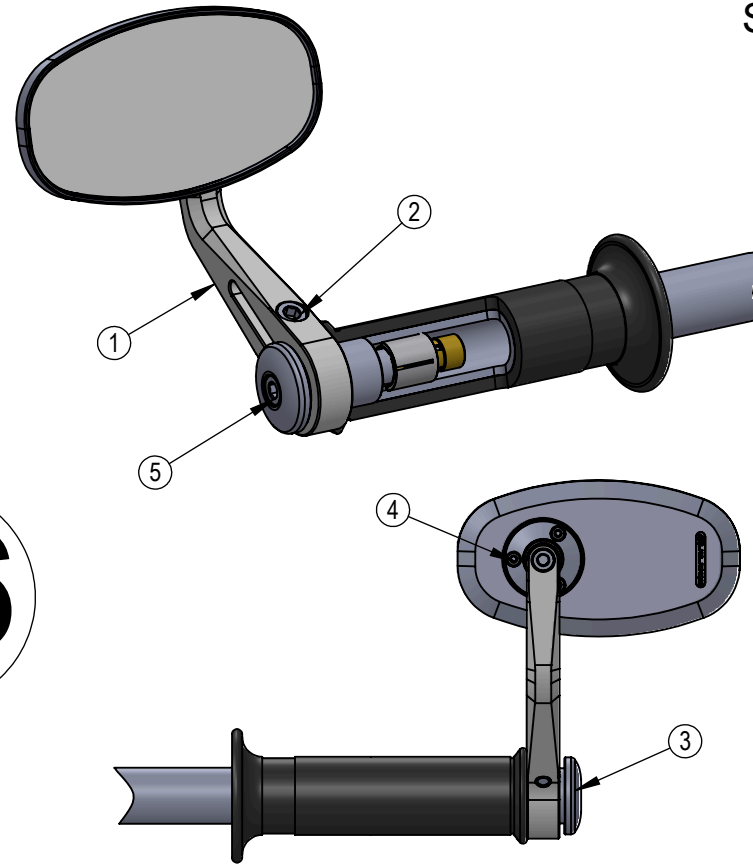

DO NOT SCALE DRAWING		REVISION:
		
TITLE: <b>Urban Mirror</b>		
DWG NO: <b>Installation Instructions</b>		<b>A4</b>
SCALE:		

**PROPRIETARY AND CONFIDENTIAL**

THE INFORMATION CONTAINED IN THIS DRAWING IS THE SOLE PROPERTY OF OBERON PERFORMANCE LTD. ANY REPRODUCTION IN PART OR AS A WHOLE WITHOUT THE WRITTEN PERMISSION OF OBERON PERFORMANCE LTD IS PROHIBITED.

# 26, 28 & 52 Instructions

## Preparation:

Before installing your new purchase please read and understand these instructions fully and make sure you have the required tools at hand.

1. Firstly, remove the original bar end.
2. Place the handlebar clamp (2) over the barend (5), place the handlebar cover (6) on the handlebar and fix the unit to the end of the handlebars with the M6/M8/M10 bolt(1) depending on your fitting kit.
3. Adjust the clamp position and fully tighten the M6bolt (4). The clamp is best positioned as far forward as possible and can be mounted below if required.
4. Take a few moments to carefully adjust the mirror bezel to the correct position.
10. Repeat for the other handlebar side if you have purchased a pair of mirrors.
11. Recheck the tightness of all fastenings, including the M3 Torx(T10) bolts (3) for security.
12. We suggest you apply a very small amount of thread locker to all fasteners. DO NOT use red Loctite. Periodically recheck all fastenings for tightness.

**26**

**28**

**52**

SKU: MIU-\*\*26, MIU-\*\*28, MIU-\*\*52

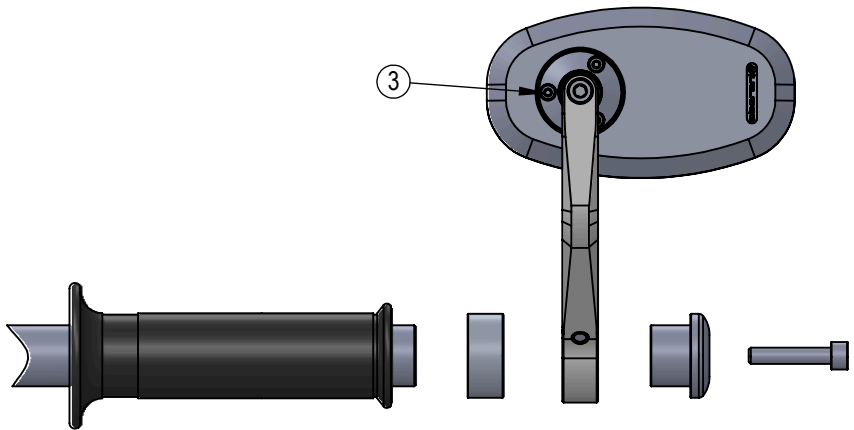
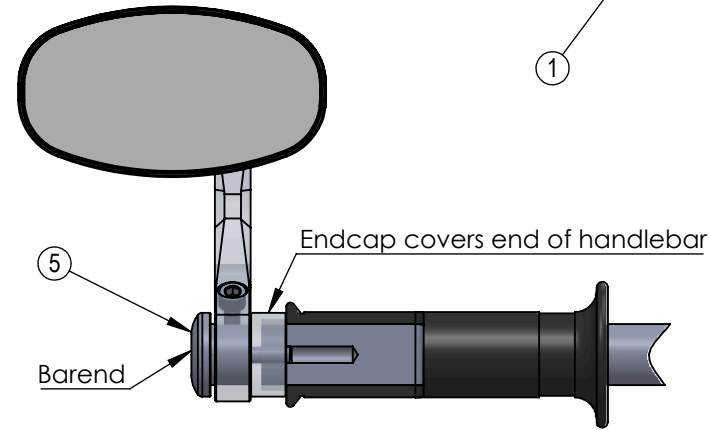
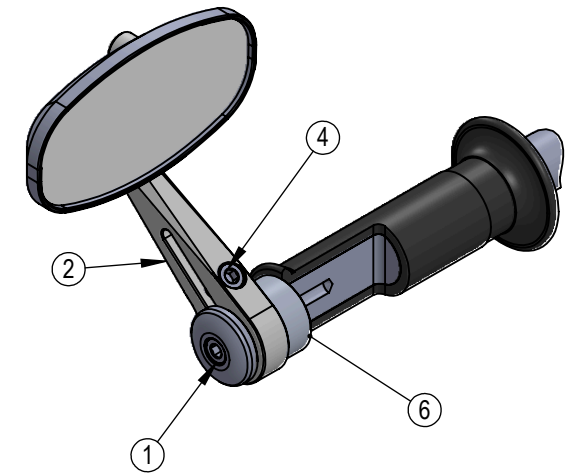

**PROPRIETARY AND CONFIDENTIAL**

THE INFORMATION CONTAINED IN THIS DRAWING IS THE SOLE PROPERTY OF OBERON PERFORMANCE LTD. ANY REPRODUCTION IN PART OR AS A WHOLE WITHOUT THE WRITTEN PERMISSION OF OBERON PERFORMANCE LTD IS PROHIBITED.

DO NOT SCALE DRAWING		REVISION:
TITLE:		
<b>Urban Mirror</b>		
DWG NO:	<b>Installation Instructions</b>	
SCALE:	<b>A4</b>	

# 60 Instructions

## Preparation:

Before installing your new purchase please read and understand these instructions fully and make sure you have the required tools at hand.

1. Firstly, remove the original bar end.
2. Apply thread locker to M12 adaptor and drive home using a 6mm hex drive. Red Loctite is recommended.
2. Place the handlebar clamp (2) over the barend (5), and fix the unit to the end of the handlebars with the M6 bolt(1).
3. Adjust the clamp position and fully tighten the M6 bolt (4). The clamp is best positioned as far forward as possible and can be mounted below if required.
4. Take a few moments to carefully adjust the mirror bezel to the correct position.
10. Repeat for the other handlebar side if you have purchased a pair of mirrors.
11. Recheck the tightness of all fastenings, including the M3 Torx(T10) bolts (3) for security.
12. We suggest you apply a very small amount of thread locker to all fasteners. DO NOT use red Loctite. Periodically recheck all fastenings for tightness.

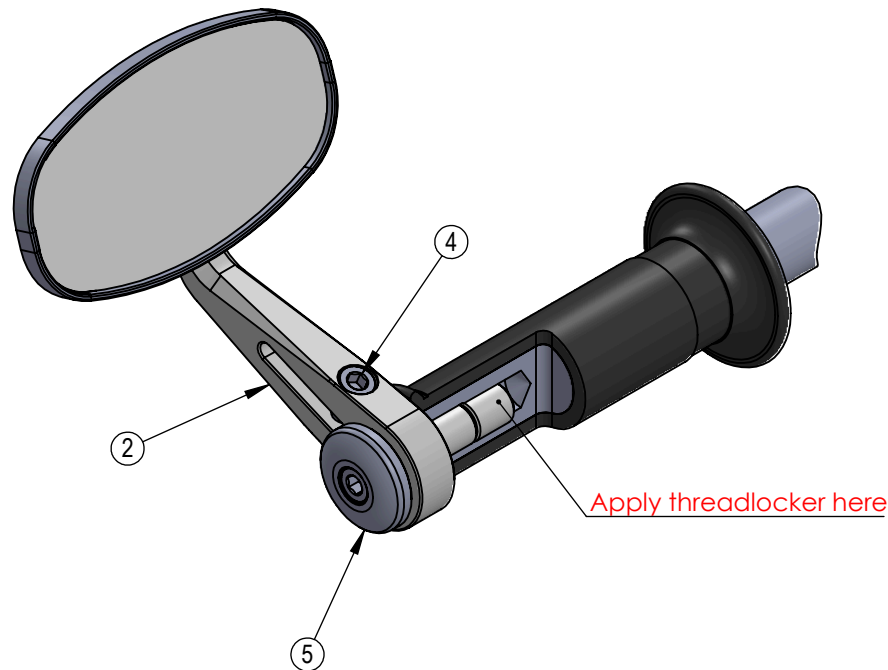

# 60

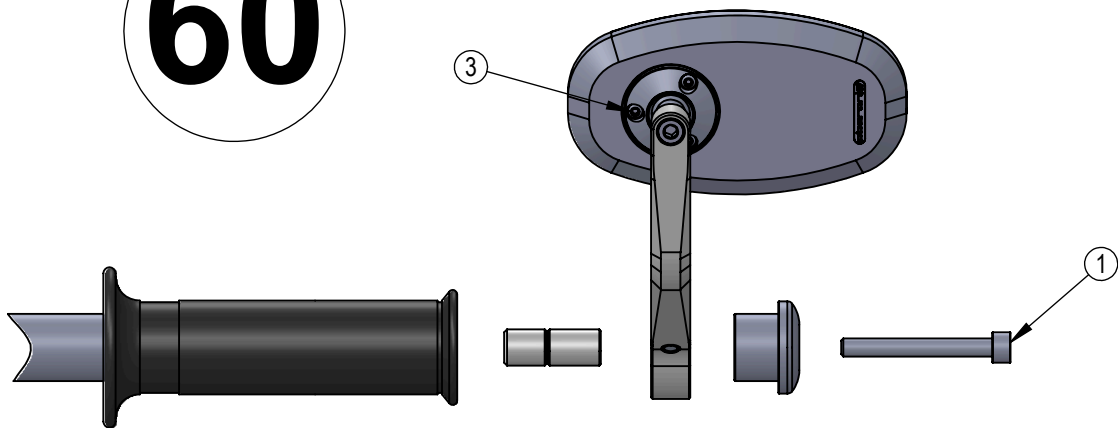

**PROPRIETARY AND CONFIDENTIAL**

THE INFORMATION CONTAINED IN THIS DRAWING IS THE SOLE PROPERTY OF OBERON PERFORMANCE LTD. ANY REPRODUCTION IN PART OR AS A WHOLE WITHOUT THE WRITTEN PERMISSION OF OBERON PERFORMANCE LTD IS PROHIBITED.

DO NOT SCALE DRAWING		REVISION:	
TITLE: <h1>Urban Mirror</h1>			
DWG NO:		A4	
Installation Instructions			
SCALE:			

# 14, 18 & 22 Instructions

SKU: MIU-**\*\*14**, MIU-**\*\*18**, MIU-**\*\*22**

**Preparation:**

Before installing your new purchase please read and understand these instructions fully and make sure you have the required tools at hand.





1. Remove the original bar end if present.
3. Check that the internal bore is clear of obstructions and burrs. Measure the internal bore and note down the size. Select the largest collet/adaptor that will fit into the hole with out forcing it in.
4. If one of the aluminium adaptors is a closer fit, slide this over the 14mm brass collet with the open end of the machined slots facing outwards.
5. For bars with an internal bore from 12mm to 13.5mm. Place the mirror clamp on the bar end(3) and push the mirror bar end into the bar using a hex drive key in the bolt. If the collet does not collapse readily then loosen the bolt further and persuade the bolt by tapping against the hex key with a soft mallet. The brass collet should collapse fairly easily and slide into the handlebar. Fully tighten the bolt (5).
6. For bars with bores above 14mm use the adaptors or dedicated collets. For 18mm or 22mm replace the complete collet. For 17mm or 19mm slide the required adaptor over the brass collet as shown in the diagram. Place the mirror clamp over the bar end(3) and push the mirror bar end into the bar using a 5mm hex drive key. Fully tighten the bolt(5).
7. Lightly tighten the M6 bolt (2) on the clamp. Take a few moments to carefully position the handlebar clamp rotationally on the handlebar. The best position is as far forward as possible. Although of course you can also 'hang' the mirror from under the bars for a different look.
6. Fully tighten the M6 bolt (2) to secure the final position of the handlebar clamp; a small drop of thread lock can be applied for a permanent fixing if required.
9. Spend as much time as you need to adjust the mirror to its 'ideal' position. Check the position and re-adjust as necessary.
10. Repeat for the other handlebar side if you have purchased a pair of mirrors.
11. Recheck the tightness of all fastenings, including the M3 Torx(T10) bolts (4) for security.
12. We suggest you apply a very small amount of thread locker to all fasteners. DO NOT use red Loctite. Periodically recheck all fastenings for tightness.

14

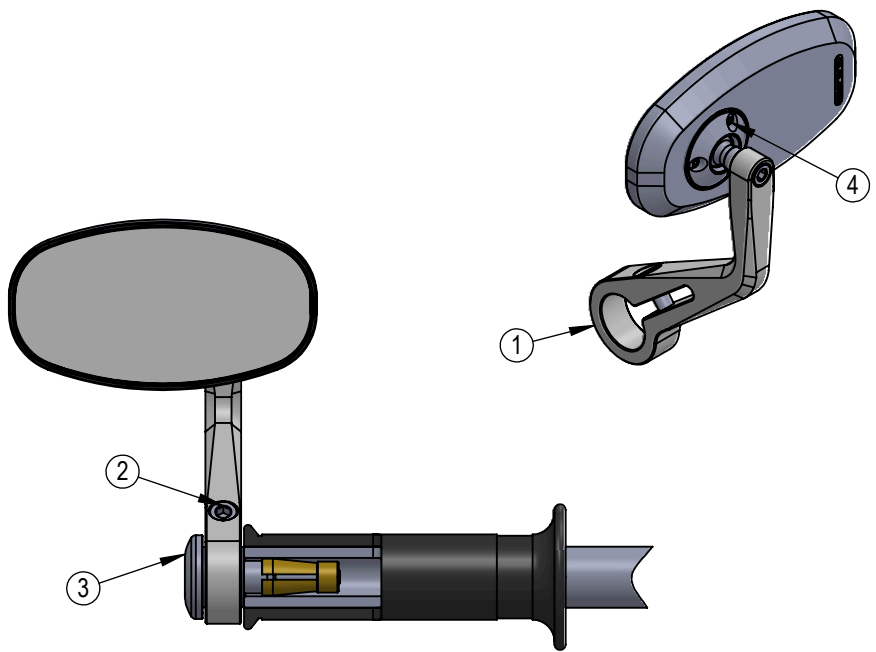
18

22



- 17mm Adaptor 
- 19mm Adaptor 
- 18mm Collet 
- 22mm Collet 

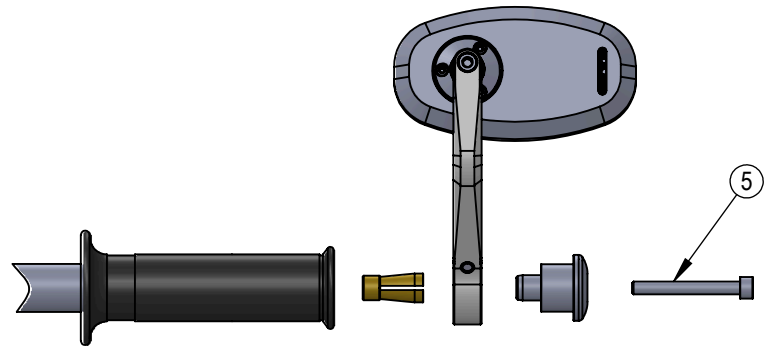

**PROPRIETARY AND CONFIDENTIAL**

THE INFORMATION CONTAINED IN THIS DRAWING IS THE SOLE PROPERTY OF OBERON PERFORMANCE LTD. ANY REPRODUCTION IN PART OR AS A WHOLE WITHOUT THE WRITTEN PERMISSION OF OBERON PERFORMANCE LTD IS PROHIBITED.

DO NOT SCALE DRAWING		REVISION:	
			
TITLE: <h1>Urban Mirror</h1>			
DWG NO:		A4	
Installation Instructions			
SCALE:			