

ITEM NO.	DESCRIPTION	QTY.
1	Fuel Filler Cap	1
2	Fuel Filler Body	1
3	Cap Base Sealing O-Ring	1
4	Cap Sealing O-Ring	1
5	Fuel Tank to Body Sealing O-Ring	1
6	M5 x 8mm Cap Head Bolt	4
7	M5 x 20mm Cap Head Bolt	4

Fitting Instructions

A direct replacement for Suzuki models with 7 & 8 bolt head visible pattern on the original item.

1. The fuel kit is supplied pre assembled and only requires simple fixing to the bike.
2. Remove the original assembly complete from the petrol tank.
3. Locate the Tank to Body sealing O-Ring (#5). Position the seal in the recess on the underside of the main body (#2). The petroleum jelly is there to temporary hold the seal in place whilst fitting.
4. VERY carefully lower the assembly into place without disturbing the seal. Loosely fit the M5 x 20mm (#7) cap head bolts into position and tighten down evenly. This will compress the Body Sealing O-Ring to the spout of the tank forming a fluid tight seal.
5. The fuel filler kit is now ready for use. NEVER over tighten the cap (#1). Only a gentle twist is needed for a positive seal. The O-Ring (#3) is there to prevent over tightening.

N.B
The seals are made from a special material called Viton which is designed for petroleum use. NEVER substitute these seals with anything else.

DO NOT use with the O-Rings removed.

SAFETY is of paramount importance. Please ensure this product is correctly fitted and tested before using you motorcycle.

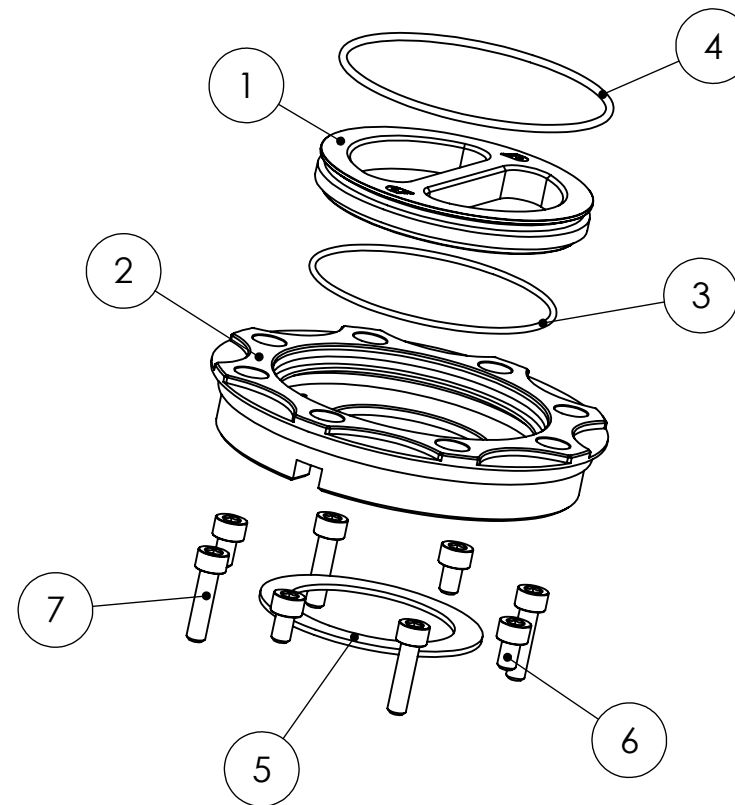

UNLESS OTHERWISE SPECIFIED:
DIMENSIONS ARE IN MILLIMETERS
SURFACE FINISH:
TOLERANCES:
LINEAR:
ANGULAR:

FINISH:

DEBUR AND
BREAK SHARP
EDGES

DO NOT SCALE DRAWING

REVISION



NAME	SIGNATURE	DATE	MATERIAL:	WEIGHT:
DRAWN				
CHK'D				
APPV'D				
MFG				
Q.A				

TITLE:

FUE-7005

DWG NO.

Installation Instructions

A4

SCALE:1:2

SHEET 1 OF 1