

ITEM NO.	DESCRIPTION	QTY.
1	Fuel Filler Cap	1
2	Fuel Filler Body	1
3	Cap Base Sealing O-Ring	1
4	Cap Sealing O-Ring	1
5	Yamaha 1.5mm Body Gasket	1
6	M5 x 8mm Cap Head Bolt	5
7	M5 x 25mm Cap Head Bolt	3
8	MV/Ducati 3mm Body Gasket	1

## Fitting Instructions

A direct replacement for MV/Ducati/Yamaha models with 5 bolt head visible pattern on the original item.

1. The fuel kit is supplied pre assembled and only requires simple fixing to the bike.

2. Remove the original assembly complete from the petrol tank.

3. Locate the Fuel Filler Body Gasket.  
MV/Ducati 3mm (#8) - Yamaha 1.5mm(#5). Position the seal in the recess on the underside of the main body (#2). The petroleum jelly is there to temporary hold the seal in place whilst fitting.

4. VERY carefully lower the assembly into place without disturbing the seal. Loosely fit the M5 x 25mm (#7) cap head bolts into position and tighten down evenly. This will compress the Body Sealing O-Ring to the spout of the tank forming a fluid tight seal.

5. The fuel filler kit is now ready for use. NEVER over tighten the cap (#1). Only a gentle twist is needed for a positive seal. The O-Ring (#3) is there to prevent over tightening.

N.B  
The seals are made from a special material called Viton which is designed for petroleum use. NEVER substitute these seals with anything else.

DO NOT use with the O-Rings removed.

SAFETY is of paramount importance. Please ensure this product is correctly fitted and tested before using you motorcycle.

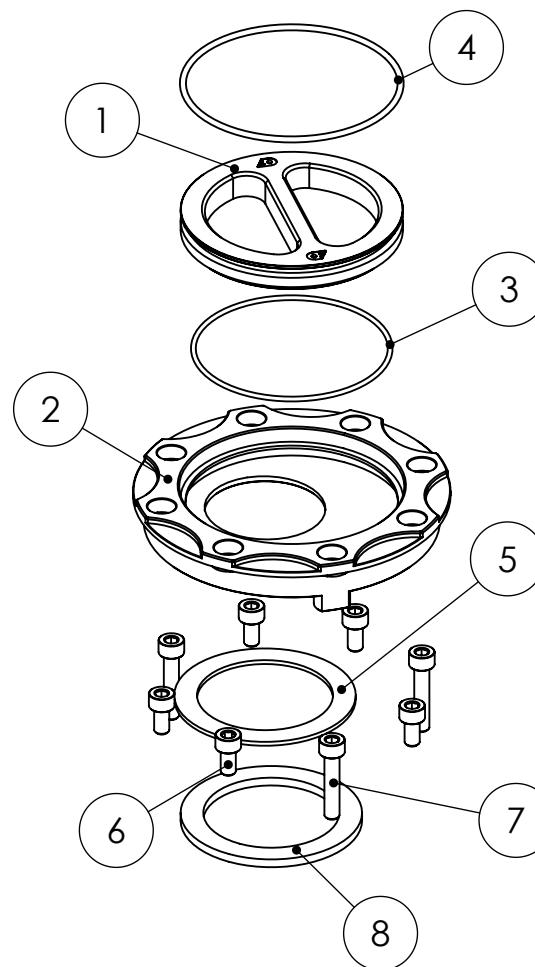

23 August 2007 13:03:50

UNLESS OTHERWISE SPECIFIED: DIMENSIONS ARE IN MILLIMETERS SURFACE FINISH: TOLERANCES: LINEAR: ANGULAR:			FINISH:	DEBUR AND BREAK SHARP EDGES	DO NOT SCALE DRAWING	REVISION
DRAWN					TITLE:	
CHK'D					MV/Ducati/ YAMAHA Fuel Filler Assembly	
APPV'D						
MFG						
Q.A						
MATERIAL:					DWG NO.	A4
WEIGHT:					99725-00 FITTING INSTRUCTIONS	
SCALE:1:1					SHEET 1 OF 1	