

ITEM NO.	PART NUMBER	DESCRIPTION	QTY.
1	99744-00	Main Body	1
2	45mmID x 60mmOD x 3mm	Tank to Body Gasket	1
3	M5 Cap Head 25mm		6
4	99701-00	Fuel Cap	1
5	O-Ring		1
6	O-Ring		1

Fitting Instructions

A direct replacement for BMW models with 6 bolt head visible pattern on the original item. BMW item number:16.11-2324336

1. The fuel kit is supplied pre assembled and only requires simple fixing to the bike.
2. Remove the original assembly complete from the petrol tank.
3. Locate the Fuel Filler Body Gasket. Position the seal in the recess on the underside of the main body (#1). The petroleum jelly is there to temporary hold the seal in place whilst fitting.
4. VERY carefully lower the assembly into place without disturbing the seal. Loosely fit the M5 x 25mm (#3) cap head bolts into position and tighten down evenly. This will compress the Body Sealing O-Ring to the spout of the tank forming a fluid tight seal.
5. The fuel filler kit is now ready for use. NEVER over tighten the cap (#4). Only a gentle twist is needed for a positive seal. The O-Ring (#5) is there to prevent over tightening.

N.B
The seals are made from a special material called Viton which is designed for petroleum use. NEVER substitute these seals with anything else.

DO NOT use with the O-Rings removed.

SAFETY is of paramount importance. Please ensure this product is correctly fitted and tested before using your motorcycle.

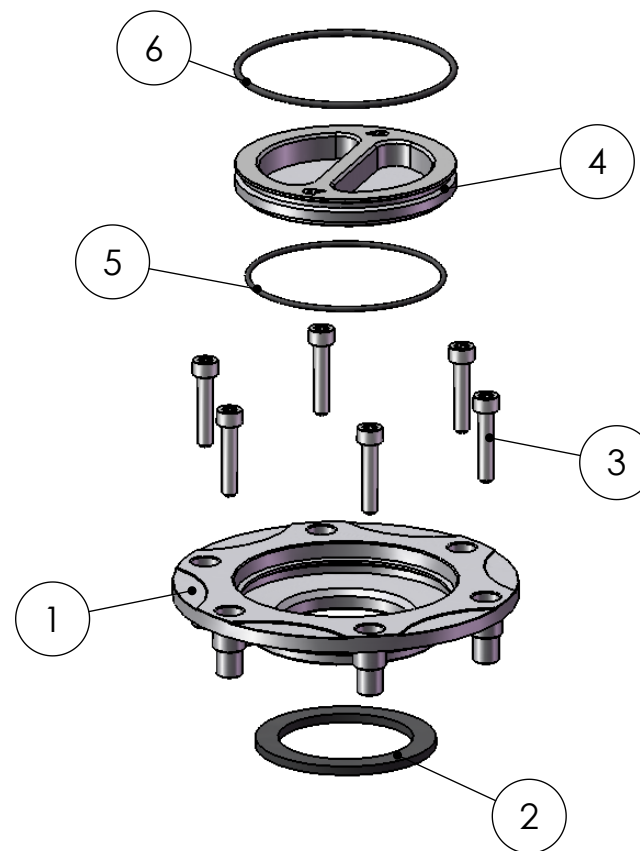

UNLESS OTHERWISE SPECIFIED: DIMENSIONS ARE IN MILLIMETERS SURFACE FINISH: TOLERANCES: LINEAR: ANGULAR:			FINISH:			DEBUR AND BREAK SHARP EDGES			DO NOT SCALE DRAWING			REVISION											
DRAWN						TITLE:						<h1>BMW Fuel Kit Instructions</h1>											
CHK'D						MATERIAL:												DWG NO.					
APPV'D						WEIGHT:												SCALE:1:2					
MFG						SHEET 1 OF 1												A4					
Q.A																							